

## INSTALLATION INSTRUCTIONS

DESCRIPTION: ALU Top Case Kit, BLACK AND SILVER  
PART NUMBER: BW3-F84A8-V0 / 2BS-F84A8-V0  
MODEL: '21+ Ténéré 700 and '12+Super Ténéré



### ⚠ WARNING

Improper loading can adversely affect handling.

- Do not exceed maximum load limit:  
Super Ténéré 1200: 10 kg (22 lbs.)  
Ténéré 700: 5 kg (11 lbs.)
- Read the Owner's Manual for important loading and tire pressure information.
- Total weight of rider, passenger, accessories, and cargo must not exceed the motorcycle load capacity shown in the Owner's Manual.
- Never ride with top case above maximum speed shown because handling could be affected.  
Super Ténéré 1200: 120 km/h (74 mph).  
Ténéré 700: 130 km/h (80 mph).  
This maximum speed may be reduced by such factors as improper loading, poor tire or overall motorcycle conditions, poor road surfaces, or adverse weather conditions.

### WARRANTY INFORMATION:

In the United States, see your Yamaha dealer for a copy of the Yamaha Genuine Parts and Accessories Limited Warranty.

### DEALER OR INSTALLER:

These instructions contain important information for future reference and *must* be given to the customer.

### NOTICE:

Installation of this kit requires a torque wrench and should be performed by an authorized Yamaha dealer or a qualified mechanic.

### PARTS LIST:

No.	Part Number	Description	Qty
--	<b>BW3-FTCAL-V0 / 2BS-F84A8-V0</b>	ALU Top Case Kit	--
①	-	Spring	1
②	-	Ball Bearing	1
③	2PP-F81C0-V0	Cylinder Lock Kit - not included in this kit	-
④	-	Cam Cover	1
⑤	-	Cap Head Bolt	2
⑥	-	Lock Latch	1
⑦	-	Dust Cover	1
⑧	-	Top Case	1

\* Part supplied with kit only and not available separately.

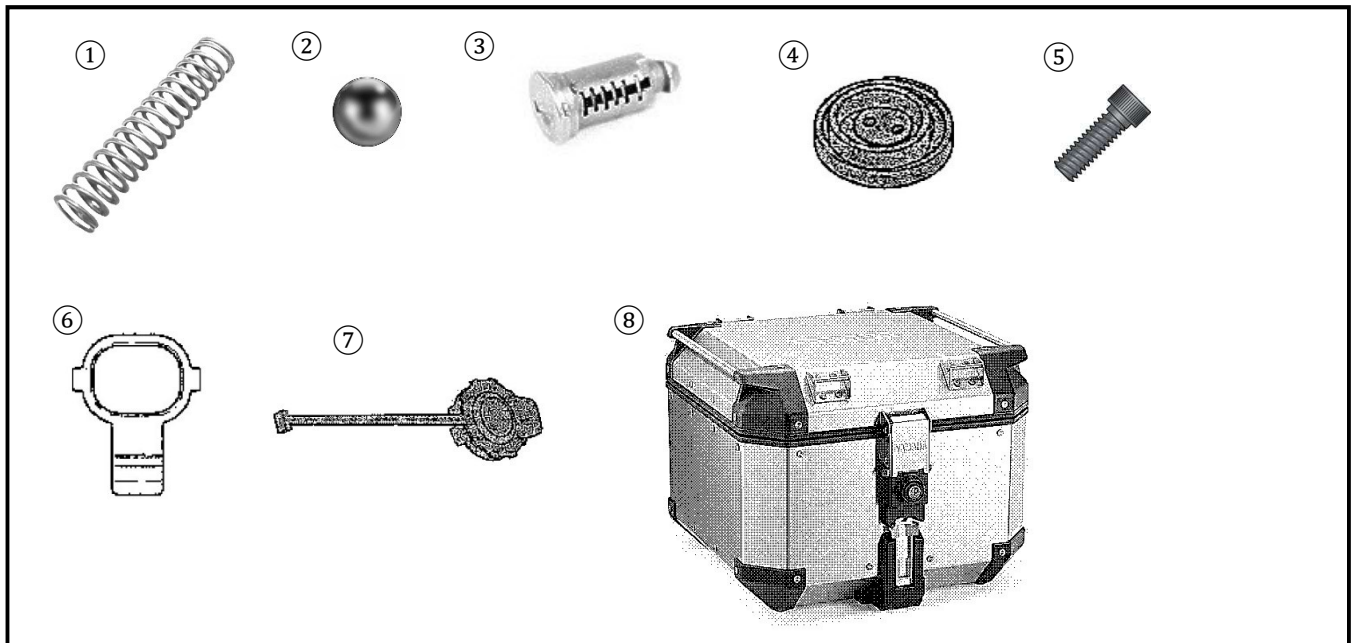

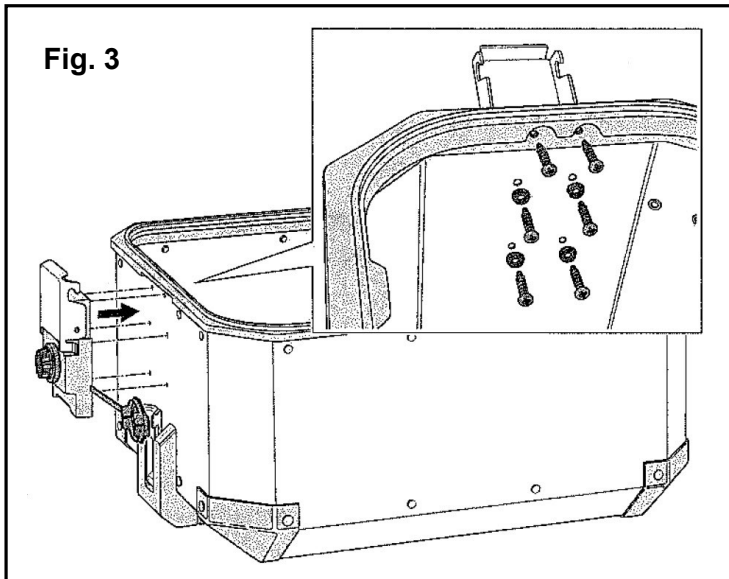
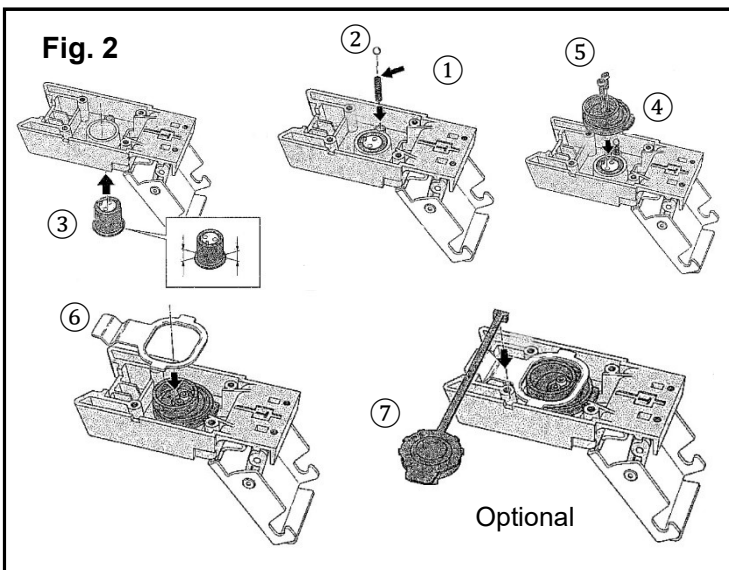
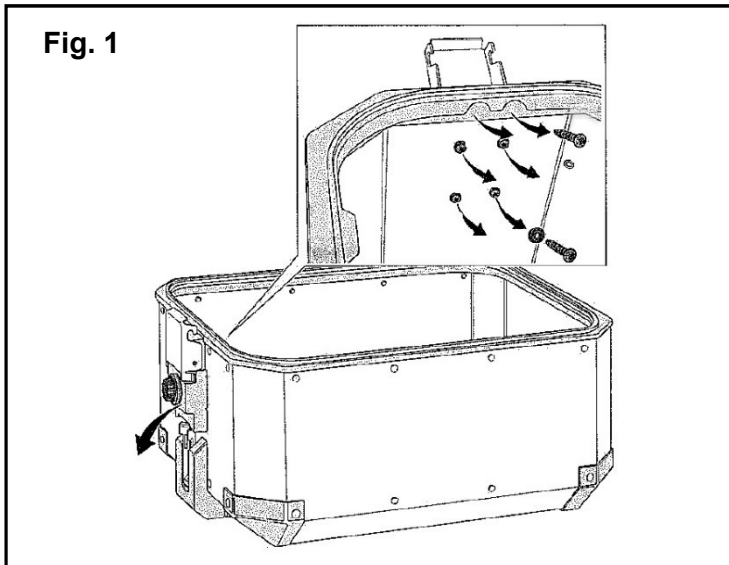

**PREPARATION:**

- Place the vehicle on a secure and level surface.
- Clean the mount surfaces before beginning installation.
- This kit requires the **BW3-F48D0-V0 Rear Carrier** for Ténéré 700 be installed first.
- This kit requires the **2BS-F84X0-V0 Top Case Mount Kit** for the Super Ténéré 1200 to be installed first.
- This instruction also shows how to install the **Cylinder Lock Kit 2PP-F81C0-V0** into the latch assembly.

**INSTALLATION:**

1. The rear carrier must be installed first to attach the Top Case.
2. Remove the latch assembly from inside the lower part of the case. Retain the hardware. (Fig. 1)
3. Insert the ③ Cylinder Lock into the latch assembly. (Fig. 2)
4. Insert the ① Spring and ② Ball Bearing into the latch assembly. (Fig. 2)
5. Attach the ④ Cam Cover with two ⑤ Cap Head Bolts. (Fig. 2)
6. Insert the ⑥ Latch over the ④ Cam Cover. There is an optional ⑦ Dust Cover that may be installed. Then reattach the latch assembly to the original location on the top case with the original hardware. (Fig. 3)

**RACK ATTACHMENT:**

1. Unlock the ⑧ Top Case and notch the rear of the case into the pegs on the Rear Carrier. Then press the ⑧ Top Case down until it engages the latch.
2. Lock the ⑧ Top Case and it will lock the case the Rear Carrier.

**TOP CASE REMOVAL:**

1. Unlock the ⑧ Top Case and pull the lower the lever and swing the Top Case upward. This will allow the rear pegs to unlatch.

Fig. 4

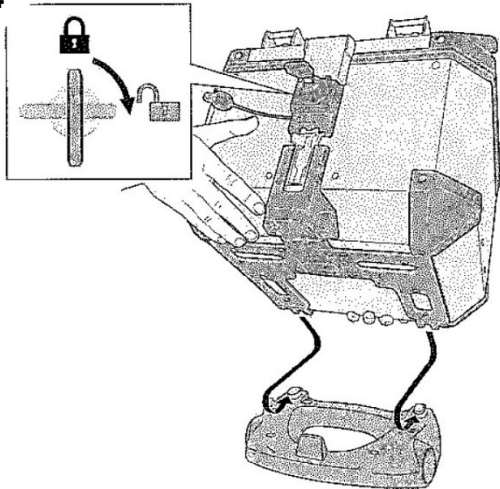

**MAINTENANCE:**

Periodically, check torque on all hardware. If loose hardware is found, re-torque to specification.

**CARE AND CLEANING:**

Clean painted metal parts with a clean soft cloth and mild soap and water solution. Rinse and dry.

**CUSTOMER SERVICE:**

For further information see your Yamaha dealer.

**ESTIMATED TIME TO INSTALL: 0.5 HRS.**

Fig. 5

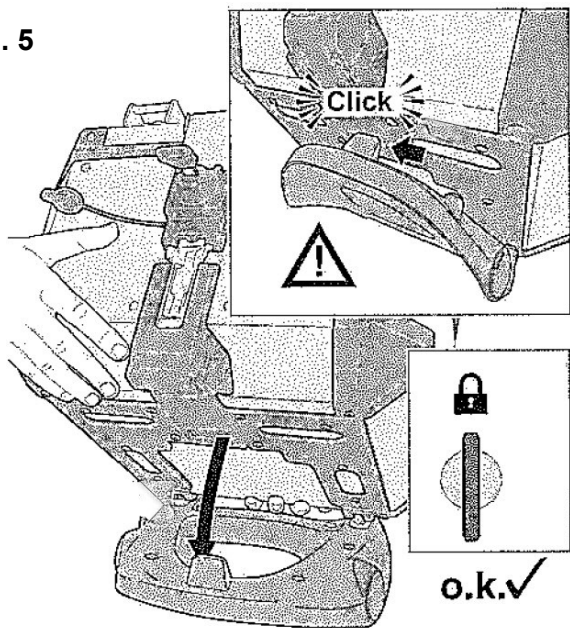

On the Ténéré 700 and Super Ténéré 1200 the Top Case is used by itself and not in conjunction with the side cases installed.

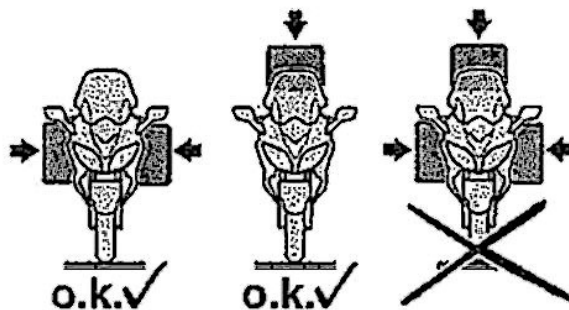

Fig. 6

